

# DATASHEET

CATEGORY: IGA TEST  
 NAME: **IGA TEST T 25**  
 REFERENCE: **AT-9006**



## PRODUCT DESCRIPTION

IGA TEST T 25 - Three-phase protector against permanent, overvoltages, with integrated MCB, nominal current 25A. Actuating time 275V→8-10s / 400V→0,1-0,2s.



IGA TEST protectors cut off the power supply when they detect a permanent overvoltage , (for example, a fault in the neutral), thus protecting the equipment installed downstream.

The protector is formed by protective coils for permanent overvoltage linked to a miniature circuit breaker (MCB).

## DATASHEET

Reference	AT-9006	
<b>&gt; DIMENSIONS</b>		
Protector dimensions	123 x 81 x 65 mm	
Number of DIN modules (DIN 43880) of the protector	7	
<b>&gt; ELECTRICALS</b>		
Nominal current	25 A	
Type of line	Three-phase	
Maximum short-circuit current	6 kA	
Nominal voltage (L-N)	$U_n$	230 V
Maximum overvoltage (L-N)	$U_c$	400 V
Actuation voltage V1 (L-N)	$U_a$	275 V
Actuation time at V1	8-10 s	
Actuation voltage V2 (L-N)	400 V	
Actuation time (V2)	0,1-0,2 s	
<b>&gt; CONSTRUCTION</b>		
Fixing	DIN Rail	

Insulation resistance	> 10 <sup>14</sup> Ω
Self-extinguishing enclosure	V-0 Type according to UNE-EN IEC 60707 (UL94)
Nr. of poles	4

> ENVIRONMENTAL

Working temperature	-5 to +40 °C
Protector location	Indoor
Enclosure protection	IP20

> CONNECTION

- Protector cables

Minimum / Maximum section	4 / 25 mm <sup>2</sup>
Screw	Philips, H2
Tightening	3 N·m

- Activation cables (S1, S2)

Minimum / Maximum section	1 / 4 mm <sup>2</sup>
Screw	Philips, H1
Tightening	1.2 N·m

> TESTS AND CERTIFICATIONS

Certificated tests according to the standard: UNE-EN IEC 61643-11

UNE-EN IEC 60898

UNE-EN 50550 (POP)

Relevant standards: UNE 21186, UNE-EN IEC 62305

Products compliant with EC requirements.

## INSTRUCTIONS

> INSTALLATION

They must be installed in series with the low voltage line, with the input at the top of the protector.

The protective coils must be installed between the lines and the neutral at the bottom of the protector.

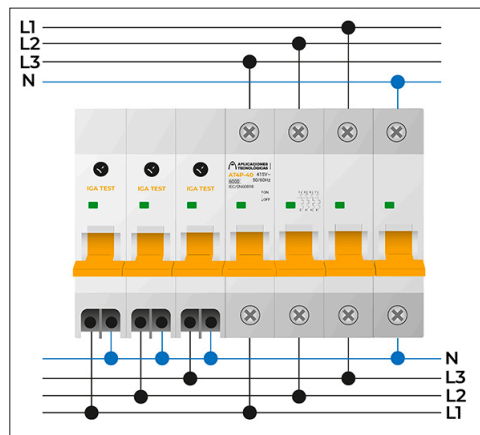

## &gt; SAFETY AND MAINTENANCE

Installation should be carried out without power in the line and can only be done by authorized professionals.

OTHER INFORMATION

---

## &gt; OTHER REFERENCES

**AT-9007:** IGA TEST T 32

**AT-9008:** IGA TEST T 40

**AT-9009:** IGA TEST T 50

**AT-9010:** IGA TEST T 63

**AT-9036:** IGA TEST T 25 PLUS

**AT-9037:** IGA TEST T 32 PLUS

**AT-9038:** IGA TEST T 40 PLUS

**AT-9039:** IGA TEST T 50 PLUS

**AT-9040:** IGA TEST T 63 PLUS

**AT-9055:** IGA TEST T 6

## &gt; RELATED PRODUCTS



**AT-8217**  
ATSUB-D T