

DATASHEET

CATEGORY: IGA TEST
 NAME: **IGA TEST T 32 PLUS**
 REFERENCE: **AT-9037**

PRODUCT DESCRIPTION

IGA TEST T 32 PLUS - Three-phase protector against permanent overvoltages and undervoltages, with integrated MCB, nominal current 32A. Actuating time 275V -> 8-10s / 400V -> 0,1-0,2s: 80V -> 0,2s / 200V -> 0,8s.



IGA TEST protectors cut off the power supply when they detect a permanent overvoltage or undervoltage, (for example, a fault in the neutral), thus protecting the equipment installed downstream.

The protector is formed by protective coils for permanent overvoltage linked to a miniature circuit breaker (MCB).

DATASHEET

| | |
|-----------|---------|
| Reference | AT-9037 |
|-----------|---------|

> DIMENSIONS

| | |
|--|------------------|
| Protector dimensions | 123 x 81 x 65 mm |
| Number of DIN modules (DIN 43880) of the protector | 7 |

> ELECTRICALS

| | | |
|--------------------------------|-------|-------------|
| Nominal current | | 32 A |
| Type of line | | Three-phase |
| Maximum short-circuit current | | 6 kA |
| Nominal voltage (L-N) | U_n | 230 V |
| Maximum overvoltage (L-N) | U_c | 400 V |
| Minimum operating voltage(L-N) | | 80 V |

- Working characteristics for overvoltages

| | | |
|----------------------------|-------|-----------|
| Actuation voltage V1 (L-N) | U_a | 275 V |
| Actuation time at V1 | | 8-10 s |
| Actuation voltage V2 (L-N) | | 400 V |
| Actuation time (V2) | | 0,1-0,2 s |

- Working characteristics for undervoltages

| | | |
|----------------------------|----------------|-------|
| Actuation voltage V1 (L-N) | U _a | 200 V |
| Actuation time at V1 | | 0.8 s |
| Actuation voltage V2 (L-N) | | 80 V |
| Actuation time at V2 | | 0.2 s |

> CONSTRUCTION

| | | |
|------------------------------|---|--|
| Fixing | DIN Rail | |
| Insulation resistance | > 10 ¹⁴ Ω | |
| Self-extinguishing enclosure | V-0 Type according to UNE-EN IEC 60707 (UL94) | |
| Nr. of poles | 4 | |

> ENVIRONMENTAL

| | | |
|----------------------|--------------|--|
| Working temperature | -5 to +40 °C | |
| Protector location | Indoor | |
| Enclosure protection | IP20 | |

> CONNECTION

- Protector cables

| | | |
|---------------------------|------------------------|--|
| Minimum / Maximum section | 4 / 25 mm ² | |
| Screw | Philips, H2 | |
| Tightening | 3 N·m | |

- Activation cables (S1, S2)

| | | |
|---------------------------|-----------------------|--|
| Minimum / Maximum section | 1 / 4 mm ² | |
| Screw | Philips, H1 | |
| Tightening | 1.2 N·m | |

> TESTS AND CERTIFICATIONS

| | |
|--|--|
| Certificated tests according to the standard: UNE-EN IEC 61643-11 UNE-EN IEC 60898 UNE-EN 50550 (POP) Relevant standards: UNE 21186, UNE-EN IEC 62305 Products compliant with EC requirements. | |
|--|--|

INSTRUCTIONS

> INSTALLATION

They must be installed in series with the low voltage line, with the input at the top of the protector.

The protective coils must be installed between the lines and the neutral at the bottom of the protector.

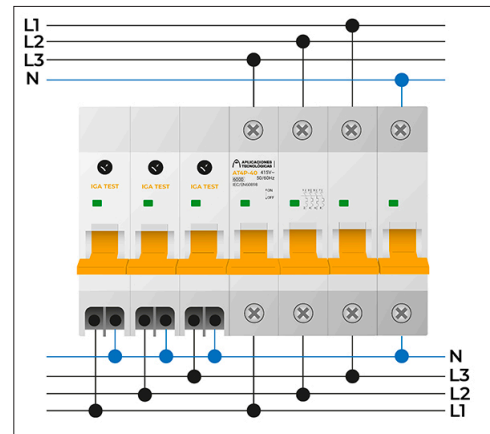

> SAFETY AND MAINTENANCE

Installation should be carried out without power in the line and can only be done by authorized professionals.

Connection to earth is a must.

OTHER INFORMATION

> OTHER REFERENCES

AT-9006: IGA TEST T 25

AT-9007: IGA TEST T 32

AT-9008: IGA TEST T 40

AT-9009: IGA TEST T 50

AT-9010: IGA TEST T 63

AT-9036: IGA TEST T 25 PLUS

AT-9038: IGA TEST T 40 PLUS

AT-9039: IGA TEST T 50 PLUS

AT-9040: IGA TEST T 63 PLUS

AT-9055: IGA TEST T 6

> RELATED PRODUCTS



AT-8217
ATSUB-D T