

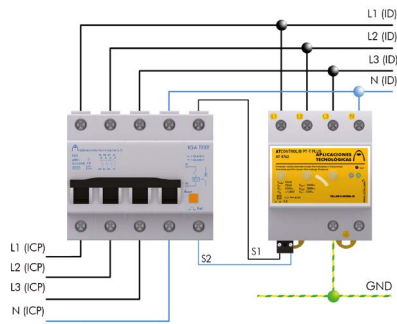

> KIT ATCONTROL/B PLUS series

> KIT ATCONTROL/B PT-T PLUS

Complete kit including self-configurable three-phase permanent and transient overvoltage and undervoltage protector, shunt release and circuit breaker



> PERMANENT OVERVOLTAGES

ATCONTROL/B series protectors trip the connected shunt release (S1, S2) when they detect a permanent overvoltage. The shunt release causes the circuit breaker to trip, protecting the equipment installed downstream.

The warning system for permanent overvoltages consists of two luminous indicators: green (correct power supply) and red (overvoltage). It has a test button to check that installation has been executed correctly.

It has a thermodynamic control device that disconnects from the electrical network in case of deterioration, and also a warning system for transient overvoltages. When the warning is yellow, the protector is in good condition. If not, replace.

> INSTALLATION

They must be installed **in parallel** with the low voltage supply line, downstream from the circuit breaker included in the kit, and connected to lines, neutral and ground. Installation should be carried out **without power running through the line**.

> TRANSIENT OVERVOLTAGES

ATCONTROL/B series protectors trip the connected shunt release (S1, S2) when they detect a transient overvoltage, driving the current to earth and reducing the voltage to a level that does not damage the connected equipment.

Tested and certified as **type 2** protector in **official** and **independent laboratories**, according to standard UNE-EN 61643-11 and GUÍA-BT-23 from the REBT. Suitable for **categories I, II, III** and **IV** equipment according to standard ITCBT-23 from the REBT.

The circuit breaker must be installed in series with the low voltage line, between the power control breaker (ICP) and the residual current breaker (ID). Connect the S1 and S2 terminals, always without voltage, to the shunt release included in the kit.

This protector is self-configurable. It automatically detects the voltage and programmes the permanent overvoltage limits.

> TECHNICAL DATASHEET

Reference:	KIT ATCONTROL/B PT-T (25 / 32 / 40 / 50 / 63) PLUS				
	AT-8776	AT-8777	AT-8778	AT-8779	AT-8780
Nominal current:	25 A	32 A	40 A	50 A	63 A
Nominal voltage:	U_n	230 V _{AC} - 400 V _{AC} (L-L)			
Maximum overvoltage:	U_c	400 V _{AC}			
Actuation voltage:	U_a	150 or 275 V _{AC} / 100 or 200 V _{AC}			
Actuation time:		@150 V _{AC} → 3 - 5 s / @230 V _{AC} → 0.1 - 0.2 s @100 V _{AC} → 3 - 5 s / @80 V _{AC} → 0.1 - 0.2 s @275 V _{AC} → 3 - 5 s / @400 V _{AC} → 0.1 - 0.2 s @200 V _{AC} → 3 - 5 s / @80 V _{AC} → 0.1 - 0.2 s			
Nominal voltage for the shunt release:		110 - 415 V _{AC} / 110 - 250 V _{DC}			
Maximum short-circuit current:		6 kA			
Test type according to UNE-EN61643-11:		Type 2			
Nominal discharge current (8/20 μs wave):	I_n	15 kA			
Maximum discharge current (8/20 μs wave):	I_{max}	40 kA			
Protection level (wave 1.2/50 μs):	U_p	1.4 kV			
Dimensions:		72 x 90 x 80 mm (4 modules DIN 43880)			
Dimensions MCB+ shunt release:		88 x 81 x 65 mm (5 modules DIN 43880)			
MCB cable range:		Minimum / Maximum section: 1.5 / 25 mm ²			
Coil cable range:		Minimum / Maximum section: 1.5 / 2.5 mm ² (single-stranded) or 4 mm ² (multi-stranded)			
Protector cable range:		Minimum / Maximum section: 2.5 / 35 mm ²			

Tests certified according to standards: UNE-EN 50550, UNE-EN 61643-11, UNE-EN 60898

Relevant standards: UNE 21186, NF C 17-102, IEC 62305