



## &gt; PROTECTION FOR DATA AND TELECOMMUNICATION LINES

## &gt; ATFONO SERIES

## &gt; ATFONO

Modular protector against overvoltages for telephone lines for DIN rail



> **AT-9101 ATFONO**: for two pairs of telephone lines.



> **AT-3501: RF SPD TESTER**: Radiofrequency SPD tester

Effective protection for **analogical and ADSL telephone lines** in modules containing **coordinated protection for 2 pairs of wires**.

- > Both common and differential protection recommended for this type of line.
- > Connects up to 2 pairs of lines that are very small in size (0.75 DIN modules).
- > Protection for telephone lines and also for the digital and analogical equipment connected to these lines (fax, modem, etc).
- > Includes removable module that can be replaced in the event of a breakdown or fault without needing to disconnect the wiring. The power supply is not interrupted when replacing the module.
- > It has a radiofrequency receptor in order to carry out maintenance using only an emitter kit. When the RF SPD tester is applied and the protector is working, the LED lights up green. If the cartridge is damaged, the LED does not light up.
- > Earthing system is introduced through a metal sheet opposite to the fixing on the DIN rail.
- > In normal conditions, it remains inactive without affecting line operation or producing any leakages.
- > Discharge takes place in an internal encapsulated element with no external flash.
- > Very fast response time.
- > Conductors are connected using screws, which enable them to absorb a greater amount of the overvoltage.

The ATFONO protector has been tested in **official and independent laboratories**, obtaining their characteristics according to relevant standards (shown in the table).



**Connection to earth is a must.** Earthing in the whole installation must be bonded either directly or by a spark gap and resistance should be lower than 10  $\Omega$ . If the indications on this datasheet are not fulfilled during use or installation of the protectors, the protection provided by this device could be compromised.

## &gt; INSTALLATION

ATFONO protectors are to be installed **in series** with the telephone line, at the point where the line **enters the building**, always respecting the telephone company indications.

When the 2 pieces of equipment to be protected are placed in **different buildings and interlinked**, the protection device should be placed both where the line goes into and out of the buildings.

The **recommended procedure** for installation is the following:

- 1 Cut the telephone cable.
- 2 Insert the telephone ends into the connectors. Carefully check that the input and output connections are correctly placed.
- 3 Connect the DIN rail to the earth terminal, since the overvoltage will be diverted to this element.

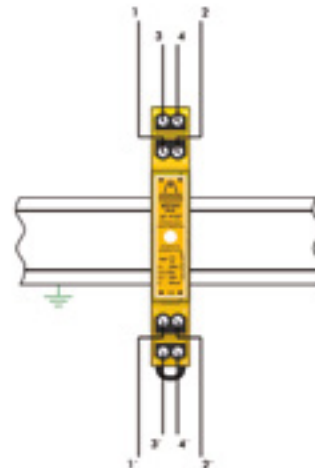



## > PROTECTION FOR DATA AND TELECOMMUNICATION LINES

### > ATFONO SERIES

#### > TECHNICAL DATASHEET

Reference:		ATFONO AT-9101
Nominal voltage:	$U_n$	130 V <sub>DC</sub>
Maximum continuous operating voltage:	$U_c$	220 V <sub>AC, DC</sub>
Nominal discharge current per line C2 4 kV (1.2/50 $\mu$ s) / 2 kA (8/20 $\mu$ s):	$I_n(C_2)$	2 kA
Total nominal discharge current C2 4 kV (1.2/50 $\mu$ s) / 2 kA (8/20 $\mu$ s):		8 kA
Protection level:	$U_p$	270 V
Maximum operating current:	$I_L$	360 mA
Series resistance:	$R_s$	15 $\Omega$
Response time:	$t_r$	< 10 ns
Working temperature:	$\vartheta$	-40 °C to +70 °C
Protector location:		Indoor
Type of connection:		Series (two ports)
No. of poles:		4
Dimensions:		13.5 x 90 x 80 mm (0.75 modules DIN 43880)
Fixing:		DIN Rail
Enclosure material:		Polyamide
Enclosure protection:		IP20
Insulation resistance:		> 10 <sup>14</sup> $\Omega$
Self-extinguishing enclosure:		V-0 Type according to UNE-EN 60707 (UL94)
Connections:		4 mm <sup>2</sup> maximum section

Certificated tests according to: UNE-EN 61643-21

Relevant standards: UNE 21186, NF C 17-102, IEC 62305

#### > DIMENSIONS (MM)

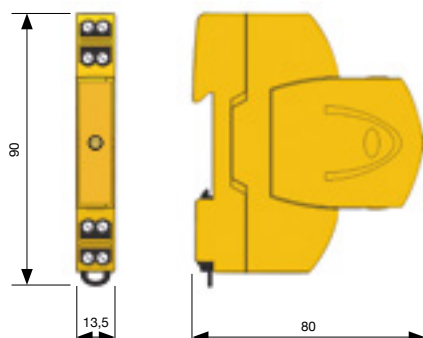

#### > ACCESSORIES



> AT-9107: ATFONO Mod.: Telephone lines up to 220 V<sub>AC</sub>